

P.O. Box 428
34 W. Oregon Ave
Creswell, OR 97426
Phone: 541-895-2197
Fax: 541-895-2361
www.thecreswellchronicle.com

2010 MEDIA KIT

EDITOR
Helen Hollyer
helen@
thecreswellchronicle.com

LEGAL & GRAPHICS
Pamela Palmer
pamela@
thecreswellchronicle.com

ADVERTISING REP
Kelly Stroble | 541-895-2197
kelly@
thecreswellchronicle.com

The Creswell Chronicle is a tabloid newspaper published every Thursday. The Creswell Chronicle is a paid circulation newspaper with 790+ subscribers and a total circulation of 1,300.

GENERAL POLICIES

- All advertising is accepted subject to approval of the publisher. Publisher reserves the right to reject advertising copy.
- The Creswell Chronicle will exercise due diligence to prevent mistakes, and cannot assume liability for errors once signed proof approval is received from advertiser. Reimbursement for typos or other errors caused by The Creswell Chronicle will be in the form of future free advertising. The Creswell Chronicle may revise advertising rates upon 30 days' notice.
- Advertiser assumes full liability for advertising, and agrees to indemnify and hold harmless the publisher from all claims, suits and related costs resulting from an advertisement.



The Creswell Chronicle

Your Community Newspaper since 1965

SUBSCRIPTIONS

SUBSCRIPTION RATES

Mail in Lane County

One Year	\$28
One Year Senior Discount (62 years & older).....	\$25
Two Year	\$51
Two Year Senior	\$42
Mail Outside Lane County-One Year.	\$44

Publication Days: Thursdays (w/exceptions of Holiday press dates)

RATES & GENERAL INFORMATION

CREDIT & PAYMENT

- New accounts must be established before credit terms can apply. Advanced payment required {prior to press date} on all new or previously "past-due" accounts.
- Payments on account are due 30 days from billing statement.
- Cash-only accounts include: new accounts, political ads, going-out-of-business ads, unapproved or poor credit, out-of-state advertisers and ads placed from motel or non-verified business or resident address.
- Contract rates are valid only after credit approval or cash-in-hand, and upon receipt of an advertising agreement signed and dated by the advertiser.

PREMIUM PLACEMENT

An additional 10% will be added to the cost of an ad given page priority placement. Placement premiums allow for priority placement of your ad, but does not guarantee placement. If ad is not placed as requested, premium charge is not assessed.

OPEN RATES

\$8 per column inch (pci)

COLOR - In addition to ad cost

One + Black = \$100 / Two + Black = \$200 / Three or Full Color = \$300

SPECIAL SECTIONS & PACKAGE RATES

Package rates can be set up with the advertising specialist. Rates can be negotiated based upon frequency of advertising, variety of package, payment schedules, and/or duration of advertising. The Creswell Chronicle runs a variety of Special Publications throughout the year. Please contact the advertising specialist to discuss individual options for package deals and Special Publications. Pre-payment may be required to receive package rate discounts.

NATIONAL ADVERTISING

\$10 per column inch

Agency Advertising Representative: Oregon Newspaper Publishers Assoc.
7150 SW Hampton, Suite 232, Portland, OR 97223
503-684-1942

ADVERTISING SPECIFICATIONS

Column and Gutter Specs

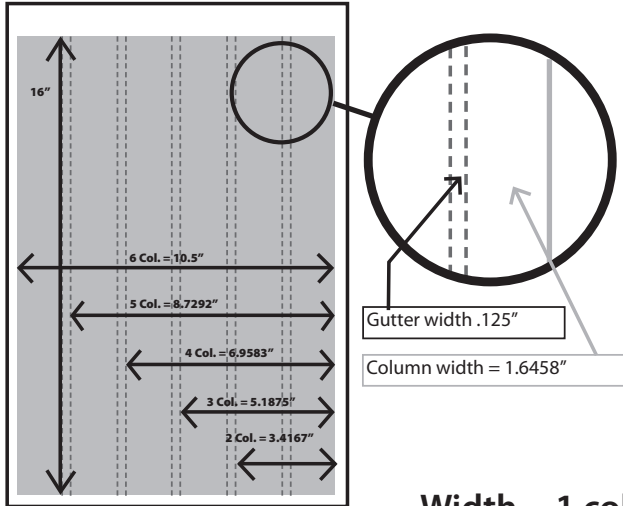

PAPER SPECIFICATIONS	
Paper Size.....	6 column \" x 16\"
Column Width.....	1.6458\"
Gutter Width.....	.125\"

WIDTH	
1 column.....	1.6458\"
2 column.....	3.4167\"
3 column.....	5.1875\"
4 column.....	6.9583\"
5 column.....	8.7292\"
6 column.....	10.5\"

HEIGHT	
Tabloid.....	16\"

Width ~ 1 column inch = 1.6458

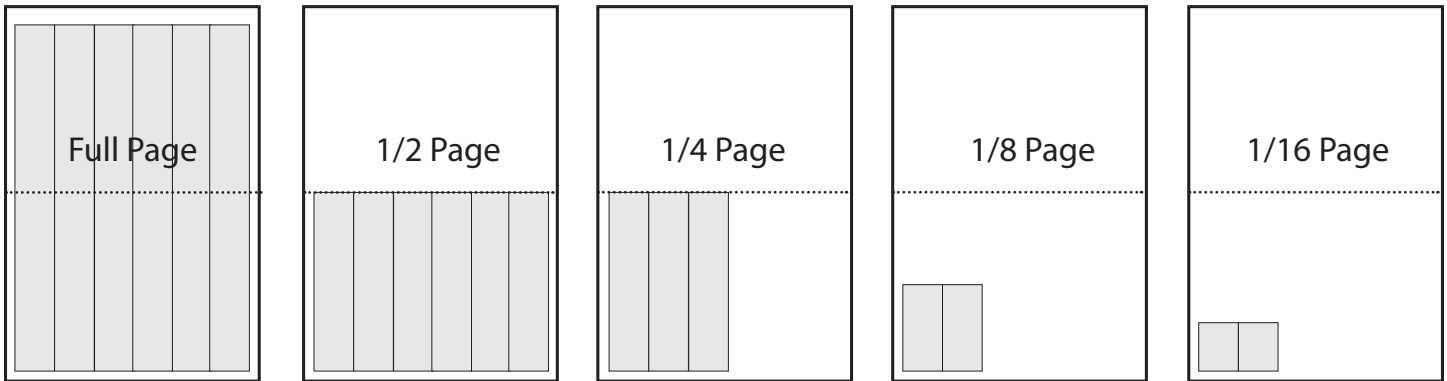

	Full Page	1/2 Page	1/4 Page	1/8 Page	1/16 Page
Columns	6	6	3	2	2
Width - In.	10.5\"	10.5\"	5.1875\"	3.4167\"	3.4167\"
Height - In.	16\"	8\"	8\"	4\"	2\"
Rate @ \$8	\$768	\$384	\$192	\$64	\$32

Costs are based on a single run, black and white at \$8 per column inch. *Modular contract rates are available for 6 month min. commitment and a 7 to 12 month commitment.

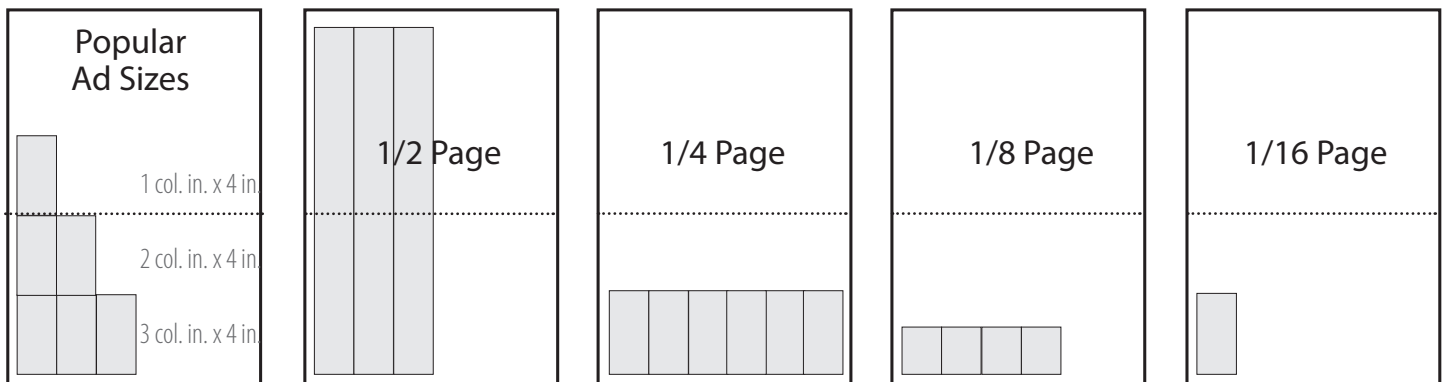

	other sizes	1/2 Page	1/4 Page	1/8 Page	1/16 Page
Columns	1 - 6	3	6	4	1
Wid.col. - In.	1.6458 x (6)	5.1875\"	10.5\"	6.9583\"	1.6458\"
Height - In.	16\"	16\"	4\"	2\"	4\"
Rate	\$8 per col. in.	\$384	\$192	\$64	\$32

Costs are based on a single run, black and white ad at \$8 per column inch. *Modular contract rates are available for 6 month min. commitment and a 7 to 12 month commitment.

SUBMISSION REQUIREMENTS

FILE SUBMISSION REQUIREMENTS

Please send grayscale (for black & white) and CMYK (for color) files at 200 dpi or better.

Acceptable file formats are PDF, TIF or JPG. PDF files are preferred.

When sending ads, please include all fonts, graphics and support files necessary to produce your document. All fonts, graphics or photos must be free of copyright restrictions. Any infringement of copyrights will fall upon the image or file provider and is not the responsibility of The Creswell Chronicle.

The Creswell Chronicle retains ownership of all staff-prepared advertising copy and illustrations. No reproduction of newspaper advertising or content is allowed without prior approval.

Send display advertising electronic files to: Kelly@TheCreswellChronicle.com or bring in on a CD or Jump Drive.

DISPLAY ADVERTISING DEADLINES

All display advertising deadlines are Fridays before noon. Holiday press schedule deadlines are Thursdays before noon.

PROOFS AND TEARSHEETS

Proofs available upon request, with the exception of classifieds. Files are usually sent via e-mail or by fax. * It is the responsibility of the client to check for spelling and informational errors on the proof. Tearsheets are provided at customer's request only. Electronic tearsheets are available also upon request.

**The Creswell Chronicle assumes no financial responsibility for errors in advertisements. It will, however, reprint the ad without charge, or cancel the charge for the portion of an advertisement that was in error, if The Creswell Chronicle was at fault.*

INSERTIONS

PREPRINTED INSERT RATES

1- or 2-sided, 8 1/2 x 11 in., 24 lb. paper.....	\$91/1,300
4-page tabloid, quarter fold	\$104/1,300
8-page tabloid, quarter fold	\$117/1,300
12-page tabloid.....	\$130/1,300

1,300 preprinted inserts - 24 lb. paper

Insert deadline is Tuesdays the week prior to the run date. Pre-payment is required on insertions.

Minimum 1,300 copies required. No postal permit may appear anywhere on insertion. Eight (8) days advance delivery to our office is needed prior to insertion run date. The Creswell Chronicle must have written confirmation of insertion orders placed directly with WOWP (our printer) or inserts left in office. Inserts must be boxed and labeled as such.

MODULAR CONTRACTS & ANNUAL BULK RATES

Modular Contract Rates

6 month minimum (\$7.00 pci)

Full Page (6 col. in. x 16 in.)	\$672
Half Page (6 col. in. x 8 in.)	\$336
Quarter Page (3 col. in. x 8 in.)	\$168
Eighth Page (2 col. in. x 6 in.)	\$84
Sixteenth Page (2 col. in. x 3 in.)	\$42
(Rates listed are per edition)	

7 to 12 month minimum (\$6.00 pci)

Full Page (6 col. in. x 16 in.)	\$576
Half Page (6 col. in. x 8 in.)	\$288
Quarter Page (3 col. in. x 8 in.)	\$144
Eighth Page (2 col. in. x 6 in.)	\$72
Sixteenth Page (2 col. in. x 3 in.)	\$36
(Rates listed are per edition)	

*Annual Bulk Contract Rates

Column Inches	Rate
125	\$7.00
200	\$6.75
250	\$6.50
300	\$6.25
500	\$6.00
750	\$5.75
1,000	\$5.50
2,000 plus	\$5.25

NOTE: Modular Contract or Annual Bulk Rates do not apply for Special Publications. *Based on a 52 week contract.

BUSINESS DIRECTORY & DINING OUT GUIDE

BUSINESS DIRECTORY ~ OR ~ DINING OUT

A **three-month** minimum contract is required for the Business Directory. All new accounts must be **PAID-IN-FULL** at time of first printing.

Advertisement rates are based on a monthly rate. Prorating will apply if the ad begins its run in the middle of the month.

Preferred ad placement is not available. Color not available.

Ad deadlines are Friday at 12 noon prior to publication date.

One change per month is allowed on Business Directory Ads.

*1 column x 2 in. Ad
Run in the
business directory
for \$30 month (3
mo. min.)

\$90 for 3 mo.*

*2 column x 2 in. Ad

Run in the business directory
for \$45 month (3 mo. min.)

\$135 for 3 mo.*

*3 column x 2 in. Ad

Run in the business directory
for \$60 month (3 mo. min.)

\$180 for 3 mo.*

CHURCH / SERVICE DIRECTORY

\$33/month - One change allowed once a month

One change per month can be made on the Business Directory/Dining Out Guide or Church Directory. Additional changes can be made at a \$5 fee for each week. Changes included text and/or images.

SPECIALTY, CLASSIFIEDS & LEGALS

NON-PROFIT ADVERTISING

\$4 per column inch

POLITICAL ADVERTISING

\$8 per column inch. Pre-payment required.

LEGAL PUBLICATION RATES

Cost Per Column Inch \$5.50 pci
Type / Kerning Point Size 7pt / 8pt
Receiving Deadline Wednesday by 5 p.m.
Cancellations Deadline Friday by 5 p.m.
Holidays may involve earlier deadline

Cancellation Fee \$5.50 pci
Payment Terms - 30 days

CLASSIFIED RATES

\$6 per 20 words or less / \$0.30 per word thereafter.
A word equals three or more characters. E.i.: a phone # equals one word. Non-business related classifieds are free with subscription to the newspaper and generally will be posted four weeks.

Classified Ads Deadline Monday Noon
Holidays may involve earlier deadline. Payment pre-paid before ad run date.

Legal & Classified Ad Page Size 6 columns x 16 inches
E-mail Legals and Classifieds to pamela@thecreswellchronicle.com

WEB RATES

WEB BUTTON/LINK: 150 pixels x 200 pixels: \$50 per month. Months falling in 30 or less charged same rate as 31 days.
BANNER ADS AND SKYSCRAPERS: Please contact the advertising rep for more information.